

DF2553

10 ... 200 Nm

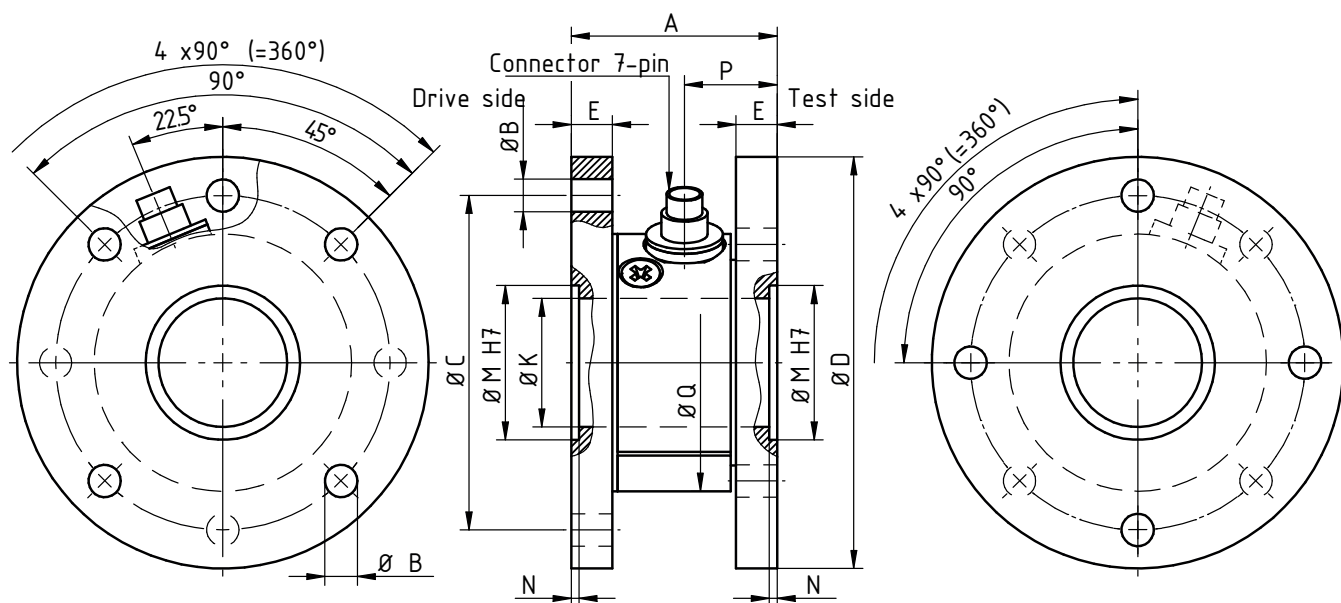

- Bride de montage des deux côtés
 - Très compact
 - Trou central
 - Classe de précision : 0.1 %
 - Raccordement électrique par connecteur
 - Grande rigidité torsionnelle
- Flange on each side
 - Very compact
 - Through hole
 - High accuracy: 0.1 %
 - Electric connection by connector
 - High torsional stiffness



Toutes dimensions en mm. Dimensions et spécifications non contractuelles. Dessins techniques disponibles sur demande.
All dimensions in mm. Dimensions and specifications do not constitute any liability whatsoever. Technical drawings are available on request.

Couple Nominal (Cn) Nominal Torque [Nm]	Dimensions - Dimension [mm]										Poids Weight [kg]
	Ø A	Ø B	Ø C	Ø D	E	Ø M	N	Ø K	P	Ø Q	
10, 20, 50	40	6.3	65	80	8	30	1.5	25	18	50	0.3
100, 200	40	8.3	65	80	8	30	1.5	25	18	50	0.7

DF2553

10 ... 200 Nm

Connexions Électriques - Electric Connections

Connecteurs 7 points - 7 pins connectors (serie 712)

Pin 1	- alim.	- excit.
Pin 2	+ alim.	+ excit.
Pin 3	Masse	Shield
Pin 4	+ signal	+ signal
Pin 5	- signal	- signal
Pin 6	Cran de calibration (option)	Calibration control (option)

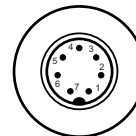

Nota : Contreprise femelle fourni - Mating plug provided

Caractéristiques Techniques - Technical specifications

Couple Nominal (Cn) Nominal Torque	Raideur Springrate	Moment d'inertie Moment of inertia J in [kg m ²]		Force axiale max. Max. axial load	Force de cisaillement max. Max. shear force
		Côté entrainant Drive side	Côté résistant Test side		
[Nm]	[Nm/rad]			[N]	[N]
10	6.77×10^3	1.08×10^4	8.83×10^5	1 100	190
20	1.28×10^4	1.08×10^4	8.83×10^5	1 600	380
50	5.15×10^4	1.10×10^4	8.87×10^5	3 100	850
100	9.44×10^4	2.83×10^4	2.56×10^4	2 500	600
200	1.97×10^5	2.84×10^4	2.57×10^4	4 200	1 200

DF2553

10 ... 200 Nm

Caractéristiques - Specifications

MÉCANIQUES	MECHANICAL		
Couple nominale (Cn)	Nominal Torque (Cn)	10, 20, 50, 100, 200	Nm
Couple statique max.	Torque static max.	130	%Cn
Couple ultime avant rupture (statique)	Ultimate torque (static)	> 300	%Cn.
Couple dynamique crête/crête max.	Dynamical torque peak/peak max.	70	%Cn
PRÉCISIONS	ACCURACY		
Classe de précision	Accuracy class	0.1	%Cn
Répétabilité	Repeatability	±0.02	%Cn
ÉLECTRIQUES	ELECTRICAL		
Tension d'alimentation	Supply voltage	2 ... 12	VCC
Résistance du pont	Bridge resistance	350	Ω
Signal de sortie	Output signal	1.0	mV/V ±0.1%
Principe de connexion	Connection type	Connecteur - Connector	
GÉNÉRALES	GENERAL		
Plage de température nominale	Nominal temperature range	-5 ... +45	°C
Plage de température opérationnelle	Service temperature range	-15 ... +55	°C
Dérive thermique de sensibilité	Temperature coefficient of sensitivity	±0.02	%Cn/°C
Dérive thermique de zéro	Temperature coefficient of zero signal	±0.02	%Cn/°C
Degré de protection (DIN EN 60529)	Level of protection (DIN EN 60529)	IP50	
Matériaux	Material	≤ 50 Nm : Aluminium / > 50 Nm : Acier - Steel	
OPTIONS	OPTIONS		
Cn spéciales	Special ranges		
Cran de calibration	Calibration control	100	%Cn
Plage de température nominale	Nominal temperature range	-30 ... +100	°C

Accessoires - Accessories



GM80



CPJ



SI USB3



F381A



Siège Social - Headquarter: Technosite Altéa - 294, Rue Georges Charpak - 74100 JUVIGNY - FRANCE
 SCAIME SAS - 294, RUE GEORGES CHARPAK - CS 50501 - 74105 ANNEMASSE CEDEX - FRANCE
 Tél. : +33 (0)4 50 87 78 64 - Fax : +33 (0)4 50 87 78 46 - info@scaime.com - www.scaime.com
 Téléchargez tous nos documents sur notre site internet - Download all our documents on our website